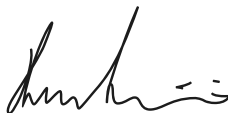

USER MANUAL

BELLAGIO REFERENCE

*Thank you for purchasing one of our units
and welcome into the Gold Note world,
where we turn High-End audio and music
into a new experience.*

Maurizio Aterini,
founder of Gold Note

A handwritten signature in black ink, appearing to read 'Maurizio Aterini', with a stylized flourish at the end.

IMPORTANT SAFETY INFORMATIONS

PLEASE NOTE

- 1 Do not disassemble any part of the product.
- 2 Do not use any part of the product for other purposes.
- 3 For service and problems of any kind, contact qualified Gold Note personnel.
- 4 Protect the product from rain, humidity and keep away from heat sources, electric and electronic motors etc. The power cord supplied must be used only on this unit.
- 5 Gold Note does not have responsibility for any improper use of this unit.

GENERIC INFORMATION

- | Read these instructions and store them.
- | Heed all warnings.
- | Follow the instructions.
- | Do not use this apparatus near water.
- | Clean only with a dry cloth.
- | Do not block the ventilation openings and install in accordance with the manufacturer's instructions.
- | Do not install near heat sources such as radiators, heat registers, stoves or other apparatus (including amplifiers) that produce heat.
- | Do not defeat the safety purpose of the polarised or grounding-type plug: a polarised plug has two blades with one wider than the other.
- | A grounding type plug has two blades and a third grounding prong. The wide blade or

the third prong are provided for your safety.

If the provided plug does not fit into your outlet, consult an electrician for replacement of the obsolete outlet. or pinched particularly at plugs, convenience receptacles, and the point where they exit from the apparatus.

- | Only use attachments/accessories specified by the manufacturer.
- | Use only with the cart, stand, tripod, bracket, or table specified by the manufacturer, or sold with the apparatus.

When a cart is used, use caution when moving the cart/apparatus combination to avoid injury from tip-over.

- | Unplug this apparatus during lightning storms or when unused for long periods of time. Refer all servicing to qualified service personnel only. Servicing is required when the apparatus has been damaged in any way (such as when the power cord or plug is damaged, liquid has been spilled or objects have fallen into the apparatus, the apparatus has been exposed to rain or moisture) and in any case when the apparatus does not operate normally or has been dropped.

This appliance has a serial number located on the rear panel.
Please record the model and serial number and retain them for your records.

MODEL

SERIAL NUMBER



CAUTION!

To reduce the risk of electric shock, do not remove cover (or back). No user-serviceable parts inside. Refer only to qualified Gold Note service personnel for service.

WARNING!

To prevent fire or shock hazard, do not expose this appliance to rain or moisture.



GOLD NOTE - Information on the correct management of waste from household Equipment pursuant to the European Directive 2012/19/EU

The crossed-out wheeled bin symbol shown on the equipment or its packaging indicates that the product, at the end of its useful life, must be collected separately from other waste to allow its proper treatment and recycling. The user must therefore deliver, free of charge, the end-of-life equipment to the centres for the separate collection of waste electrical and electronic equipment, or return it to the dealer in accordance with the procedures established by the legislation.

The appropriate separate collection of discarded equipment allows for proper recycling, treatment and environmentally compatible disposal, helping to avoid the possible dispersion of hazardous substances and negative effects on the environment and health, favouring the reuse and/or recycling of the materials of which the equipment is composed of. Illegal dumping of the product by the user involves the application of administrative sanction provided for by the legislation in force. We invite you consult the current legislation and the measures adopted by the public service operating in your country or territory.

| INDEX

EN

INTRODUCTION AND FEATURES	1
TECHNICAL SPECIFICATIONS	2
UNBOXING	3
ASSEMBLING THE TURNTABLE	7
POWER SUPPLY	22
SPEED CONTROL & FUNCTIONS	23
VTA AND AZIMUTH SETUP	24
CARTRIDGE AND TONEARM CALIBRATION	25
PRODUCT REGISTRATION	27
TROUBLESHOOTING	28
RELATED PRODUCTS	29

| INTRODUCTION AND FEATURES

OUR BEST TURNTABLE EVER

The Bellagio Reference is our exclusive limited edition turntable, a statement of precise engineering and Italian design capable of delivering exceptional High-End audio performance. Thanks to its curve-plinth architecture, the Bellagio Reference is a unique turntable made with high quality components and carefully chosen materials, such as the carbon steel platter spindle and the ceramic ball bearing, or the massive ultra-dampened platter.

PRECISELY CALIBRATED MOTOR

The Bellagio Reference is powered by our very best proprietary control system developed with a Quadral-Core micro-controller and enhanced by an audio converter. The power control reshapes the AC wave to perfectly drive the 12V synchronous motor removing vibrations while improving its torque to deliver the greatest dynamic and the finest detail.

The power supply of the Bellagio Reference electronically controls the 33 $\frac{1}{3}$ rpm and 45rpm mode as well as the fine speed adjustment, storing the settings into its memory. This special power supply leverages a super inductive dual-choke hybrid design - with a filter on the analogue stage and a dual choke design. Our proprietary Dual-Choke design perfectly filters the voltage to eliminate any interference and electrical noise from the power system, providing an effective shielding from the power grid and creating the ideal working environment for the turntable to perform at the best.

UNIQUE ARCHITECTURE WITH CURVED PLINTHS

The Bellagio Reference features five different curved plinths to deliver great stiffness and indeformability through its architecture, which also allows superb control over resonances. The plinths are connected with aluminium spacers, each of different thickness, joined together to minimise vibrations and completely insulate the platter from the surrounding environment. The large feet are custom design and made of aluminum from solid blocks through CNC machining. For the Bellagio Reference, we designed one of the best bearing/spindle systems ever made, entirely made of carbon steel, hardened and rectified, then polished to guarantee the best smoothness to the rotation of the platter. Polished bronze is used for the bearing housing, engineered to reach a 1/100 millimetre tolerance with the spindle.

The new hourglass-shaped motor pulley stops the transmission of any vibration thanks to its dampening qualities. It's precisely machined and then polished to achieve perfectly smooth surfaces in order to guarantee low noise and high rotational stability.

TECHNICAL SPECIFICATIONS

EN

MAIN FEATURES

- | Wow & flutter:
0,05%
- | Rumble:
-83db
- | Speed:
33 $\frac{1}{3}$ rpm and 45 rpm \pm 0,1%
- | Speed changing:
Electronic with fine pitch control
- | Transmission:
70 shores elasticity rectified black EPDM
Deluxe belt
- | Motor:
12V high-torque synchronous AC,
decoupled
- | Platter:
90mm thick ultra-dampened POM
- | Platter spindle:
Split-spindle™ clamping design
- | Platter bearing:
Ceramic 5mm ball bearing

POWER

- | Power supply:
100-240V with automatic selection;
50/60Hz
- | Power consumption:
25W
Standby < 1W

DIMENSIONS AND WEIGHT

- Dimensions:
530mm W 350mm H 500mm D
- Weight:
32Kg

FINISHES

- UPPER PLINTH:
Black polished acrylic
- MAIN PLINTH:
Black polished acrylic and titanium
- METAL PARTS:
Black

| UNBOXING

LAYER A

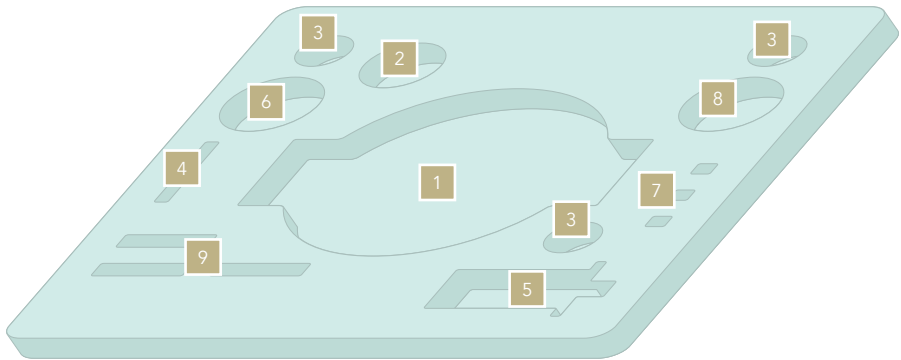

1 Platter with 18 counterweights (already assembled)

2 Platter clamp

3 Turntable foot (3x)

4 Platter spindle clamp

5 Motor

6 Tonearm flange

7 Conical spacer for tonearm flange (3x)

8 Tonearm board with adapter (already assembled)

9 Threaded bar sleeve (3x)

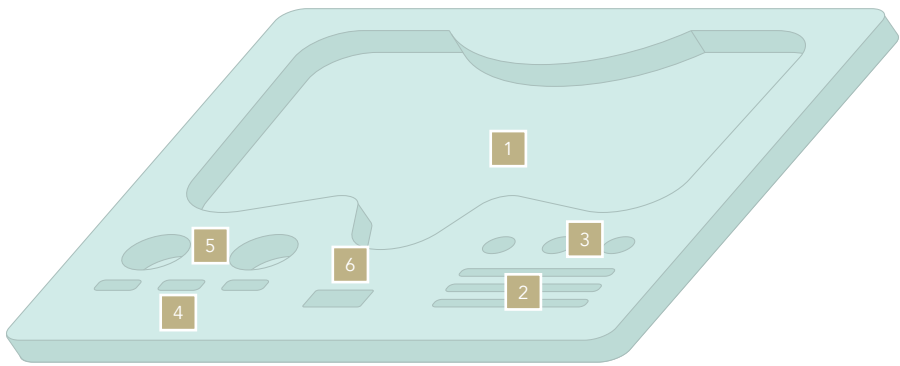
LAYER B

1 Upper plinth

2 Titanium threaded bar with nut (3x)
(already assembled)

3 Titanium support for the upper plinth
(3x)

4 Tonearm flange bottom support (3x)

5 Dome cover (2x)

6 Conical cover

LAYER C

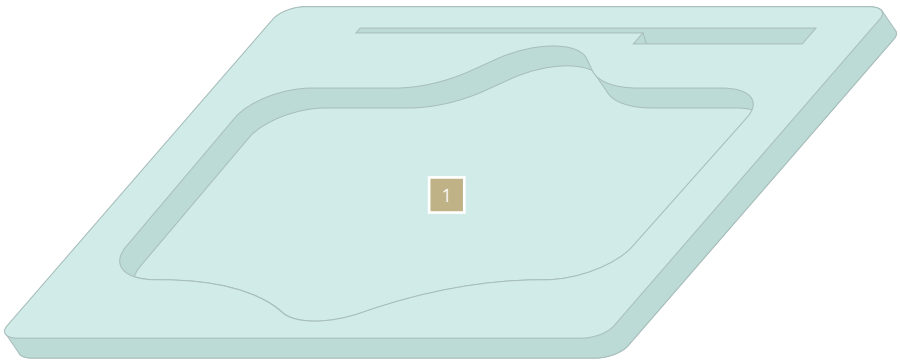

1 Main plinth

LAYER D

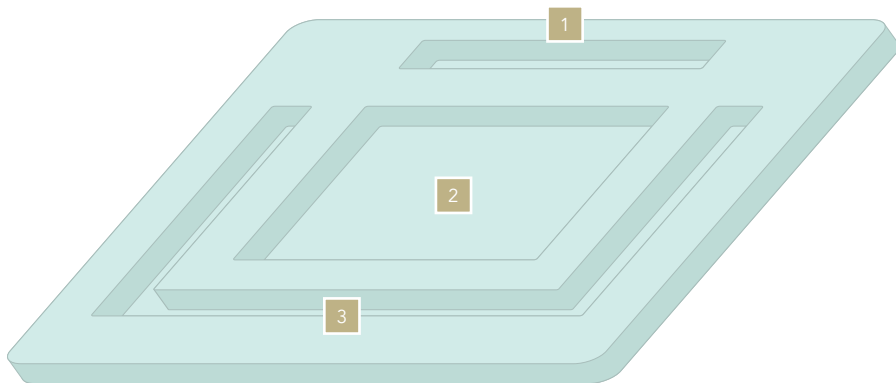

BOX 1

- 1 | Transmission belt (2x)
- | Oil for the spindle/bearing
- | 13mm titanium wrench
- | 10mm titanium L wrench
- | 5mm Allen wrench
- | 3mm Allen wrench
- | 2mm Allen wrench
- | 6x60mm Allen screws (for the motor) (2x)
- | 4x40mm Allen screws (for the arm board) (3x)
- | Brass spike pad (3x)
- | Gloves

BOX 2

- 2 | PST-10 power supply
- | Felt mat
- | Stroboscope

BOX 3

- 3 | Power cord

| ASSEMBLING THE TURNTABLE

STEP 1

Take the titanium threaded bars located in B2 (layer B, number 2), these have already been assembled as shown in the image and are ready to be used.

PLEASE NOTE: Each bar has two O-rings already installed and the nut, these should be spaced as shown in the image below.

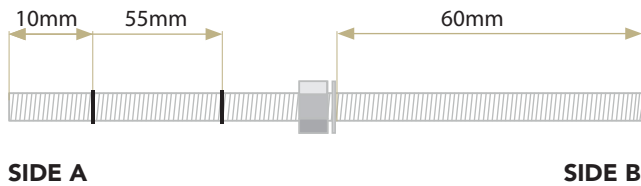

STEP 2

STEP 2.1

Screw the bars into the main plinth with the side B facing downwards and going into the plinth. Side A, where the O-rings are located, faces upwards.

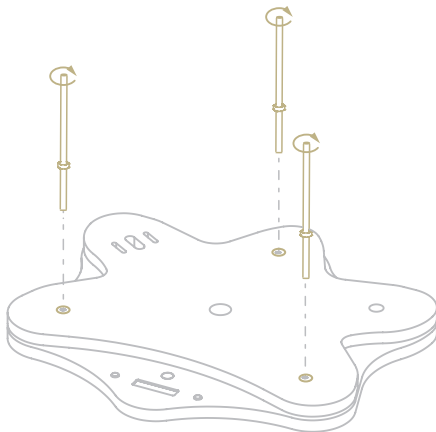

STEP 2.2

On the bottom side of the main plinth, the bars should protrude for 15mm.

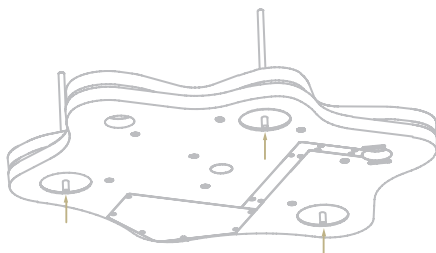

STEP 2.3

Tighten the nuts on the bars using the 13mm wrench to lock them in place as they will support the upper plinth.

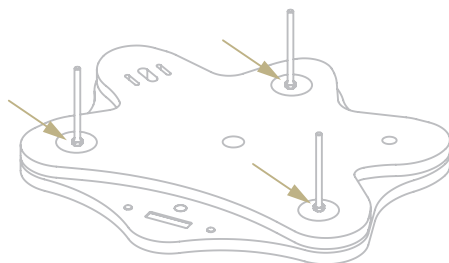

STEP 3

Take the 3 feet located in A3 (layer A, number 3) and install them screwing them on the threaded bars as shown in the pictures below.

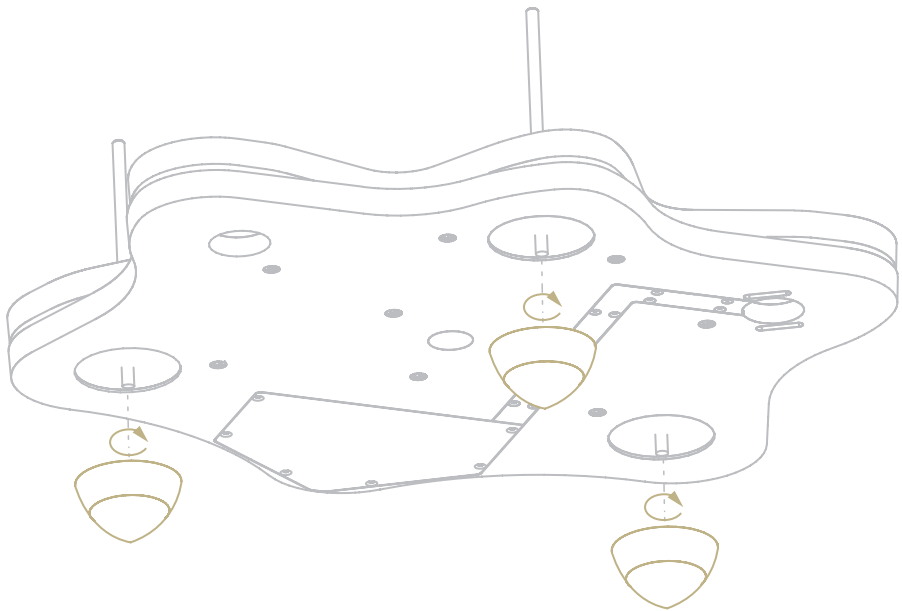

STEP 4

Take the 3 threaded bar sleeve located in A9.

Install them ensuring the open side faces down and slide them onto the threaded bars as shown in the pictures below.

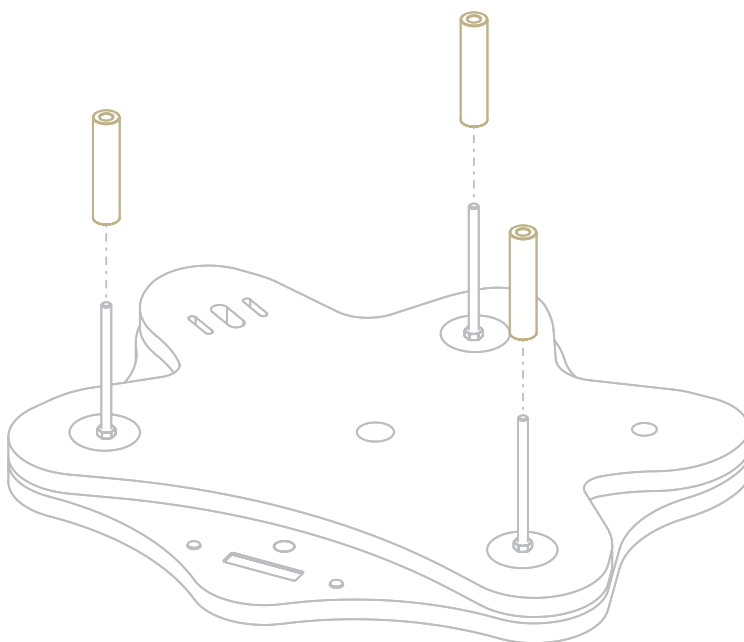
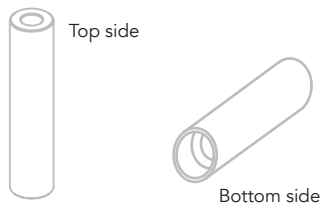

STEP 5

Take the titanium supports for the upper plinth located in B3.

Install the supports on the bars by screwing them until they touch the sleeves.

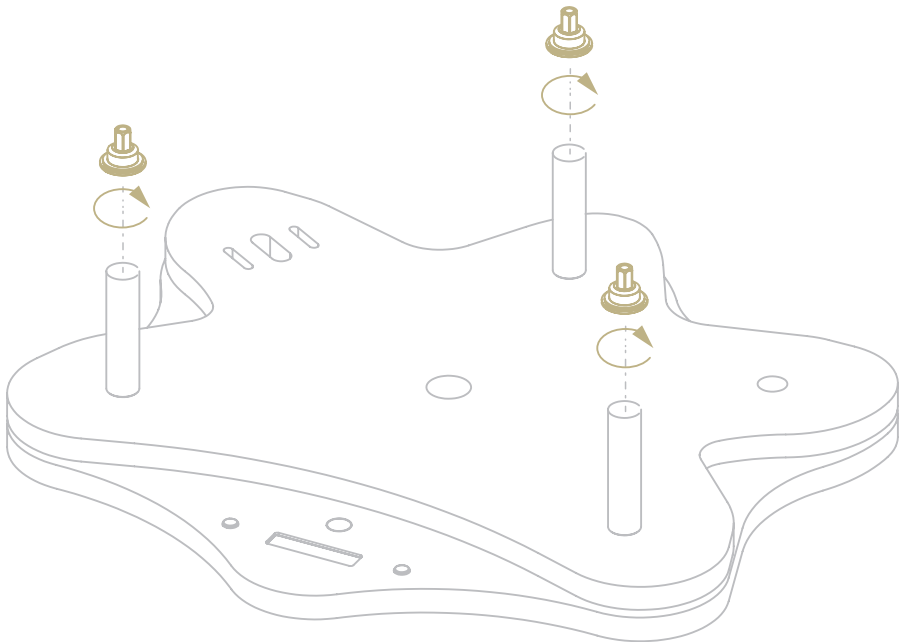

STEP 6

Take the motor located in A5 and the 6x60 Allen screws (2x) located in the BOX 1 of the layer D.

STEP 6.1

Connect the power cable installed on the main plinth to the motor, the connector is located on the bottom side of the motor.

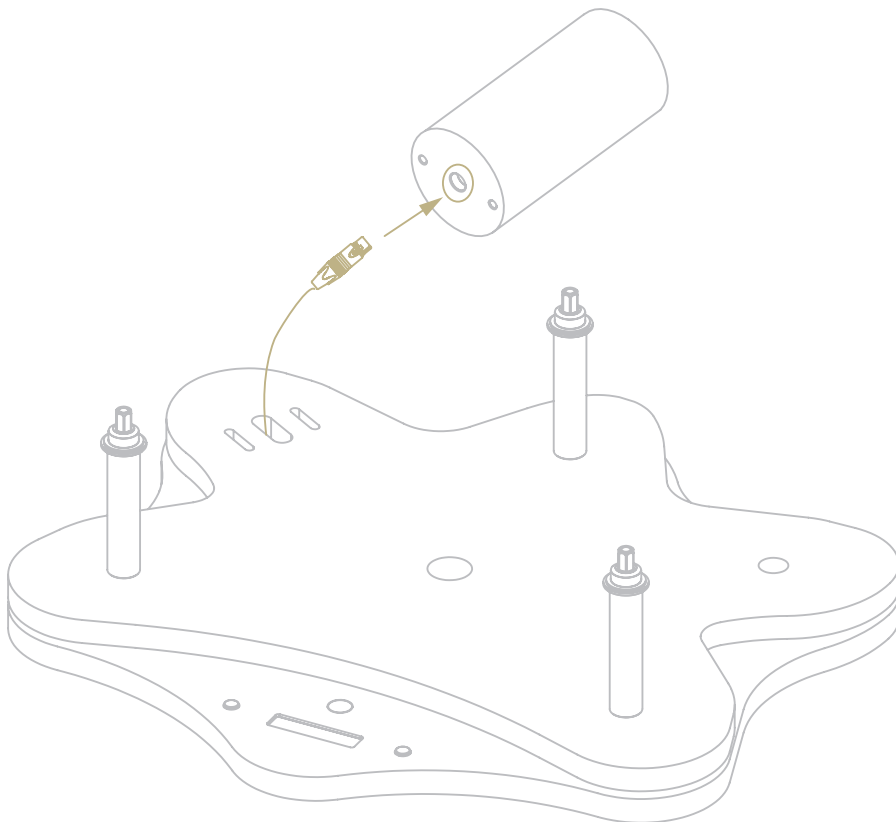

STEP 6.2

Insert the Allen screws into the slots located on each side of the cable on the main plinth ensuring that the head is on the bottom of the plinth. Gently lower the motor using the screws as guides - the screws should go into the screw holes on the bottom of the motor.

STEP 6.3

Ensure that the screws are centred and use the 5mm Allen wrench to lock the motor in place.

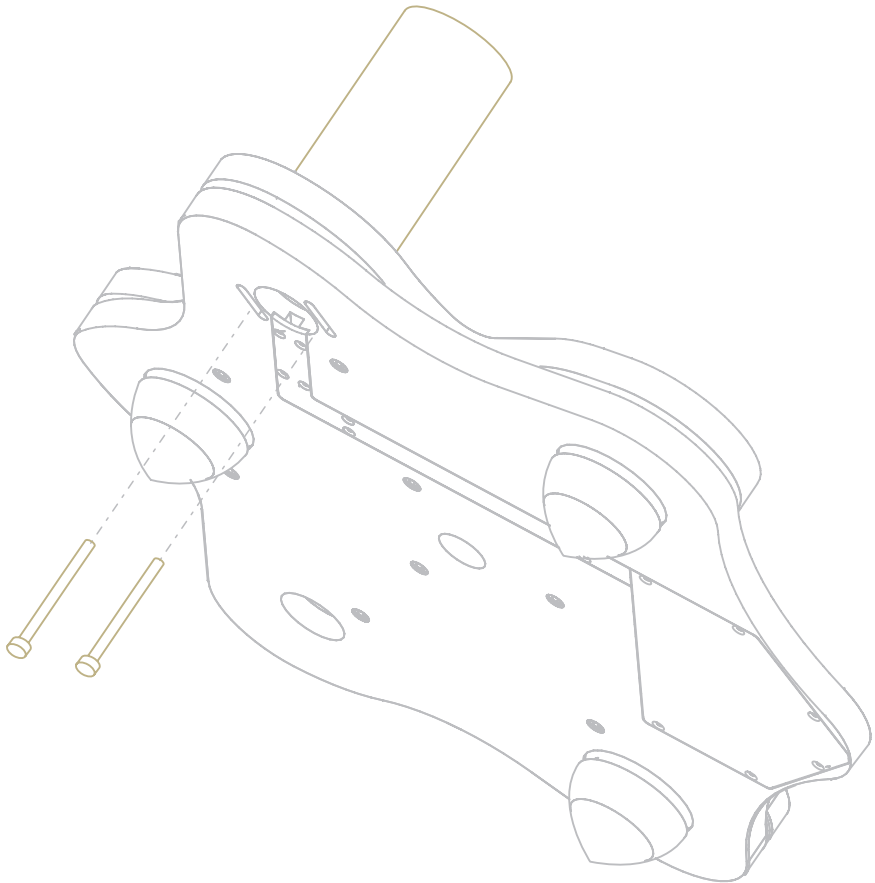

STEP 7

Prepare the upper plinth, which is located in B1.

Carefully lower the plinth onto the support bars ensuring that the areas for the pulley and the motor are cleared. Please take extra care as the plinth and motor can be accidentally damaged.

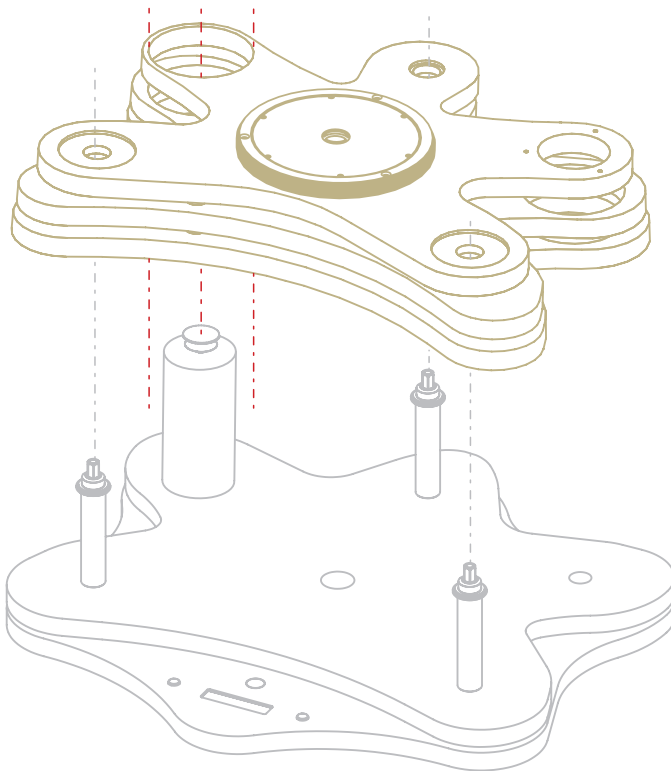
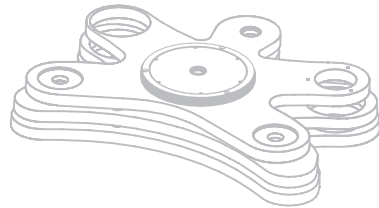

STEP 8

Take the platter located in A1 and the platter spindle clamp located in A4.

Install the platter on the upper plinth, pay attention to center it on the spindle - it should fit perfectly.

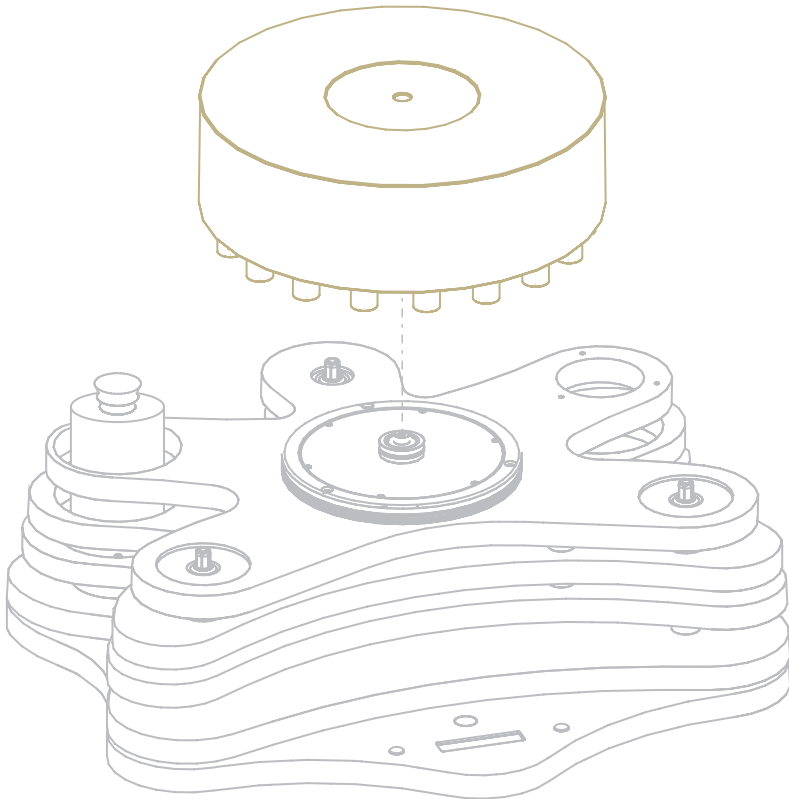

STEP 8.1

Insert the platter spindle clamp into the platter center and screw it into the spindle until locked.

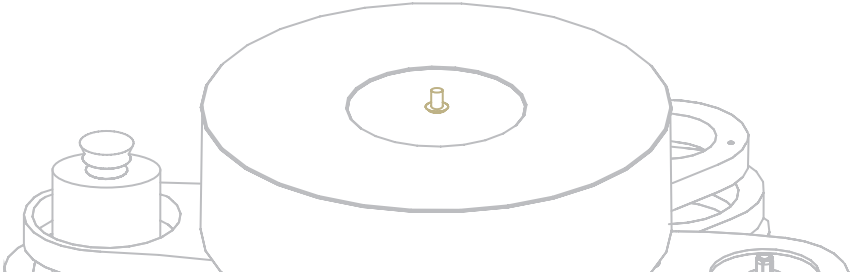
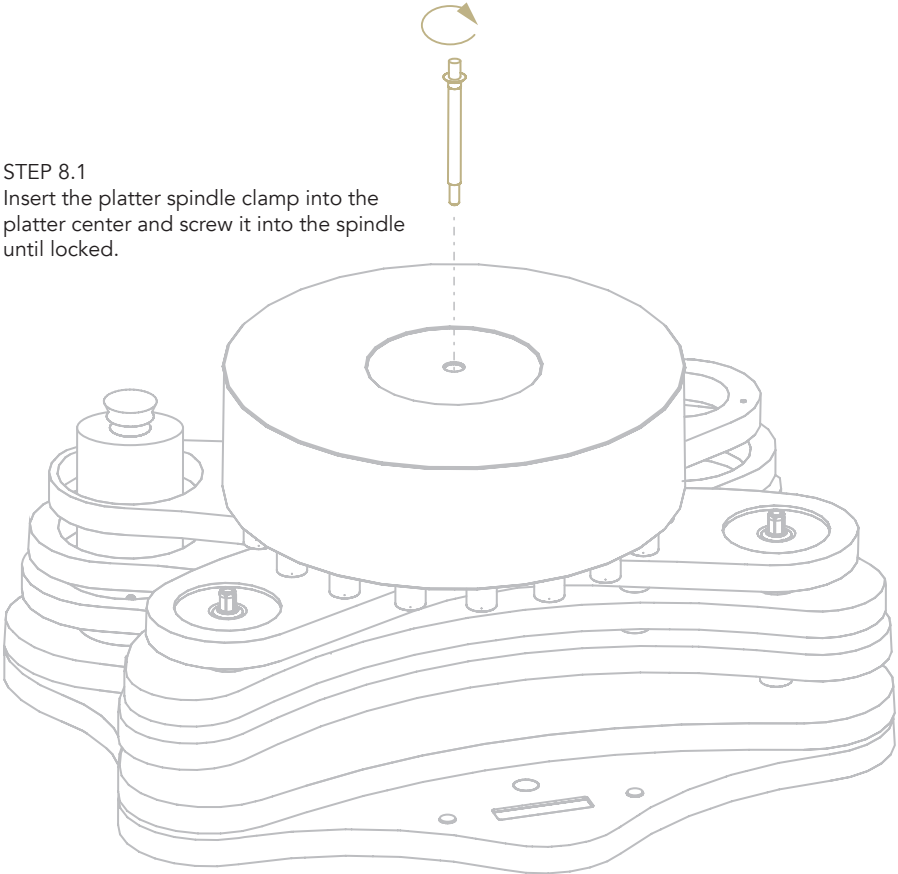

STEP 9

Prepare the following parts to assemble the tone arm support:

- | Tonearm flange, located in A6
- | 3 conical spacers for tonearm flange, located in A7
- | Tonearm board with adapter, located in A8
- | 3 supports for the tonearm flange, located in B4
- | 3 4x40mm Allen screws (for the arm board), located in D1

PLEASE NOTE: The flange adapter is designed out of axis to guarantee the compatibility with 9" tonearms. To change the position of the adapter, you can rotate it in order to fit your tonearm. Use the 2mm Allen wrench to lock and unlock the adapter.

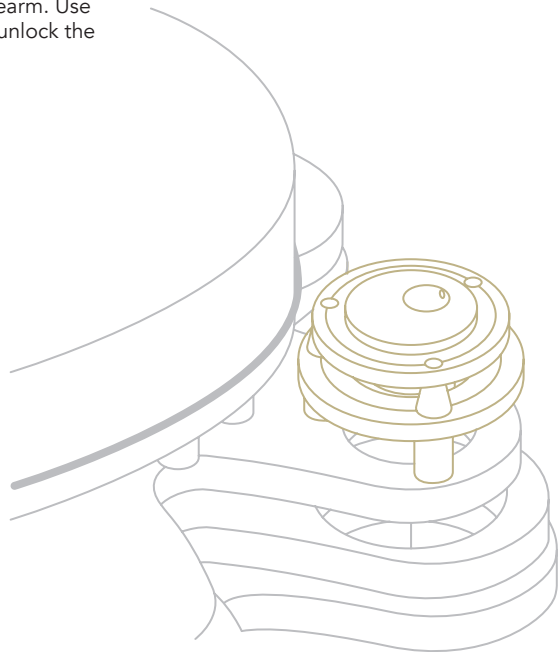
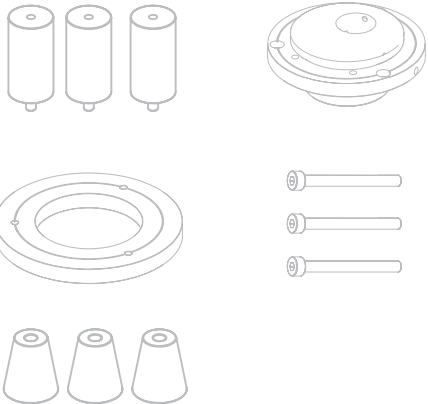

STEP 9.1

Install the supports for the tonearm flange screwing them into the upper plinth as shown in the picture.

STEP 9.2

Lay the tonearm flange on top of the supports paying attention that the holes of the flange are aligned with those of the supports.

STEP 9.3

Lay the conical spacers on top of the flange centring them on the holes.

STEP 9.4

Finally, rest the tonearm board on top, ensuring again that the holes are centred. Then insert the 4x40mm Allen screws and lock them in place with the 3mm Allen wrench.

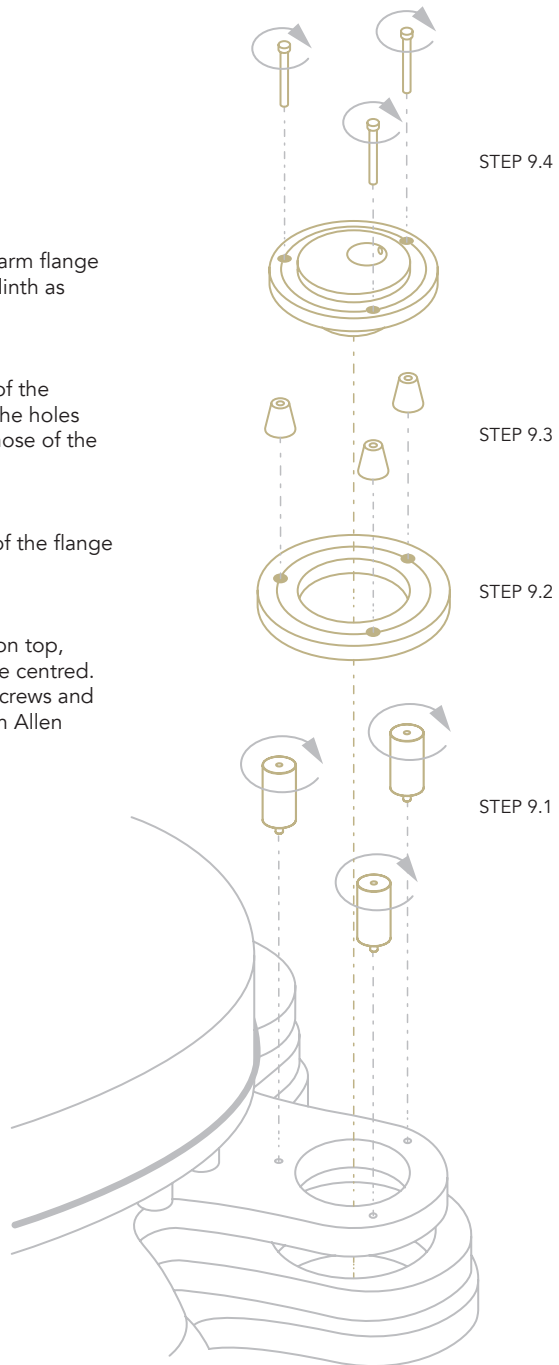

STEP 10

Take the transmission belt located in the BOX 1 of the Layer D.

Wrap the belt around the pulley first and then around the platter as shown in the picture. The belt must be positioned on the lower platter, close to the counterweights and horizontally aligned with the pulley.

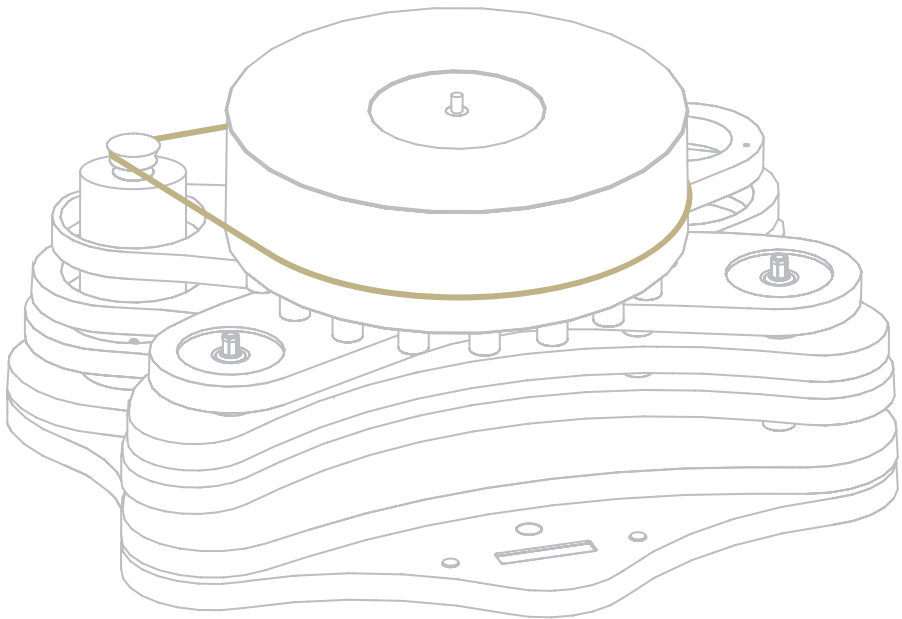

STEP 11

Check if the turntable is horizontally levelled with the help of a spirit level. To adjust the levelling, use the 10mm L wrench and rotate clockwise or counterclockwise the titanium supports installed at STEP 5.

Rotate clockwise to lower the plinth on the axis, and counterclockwise to raise it.

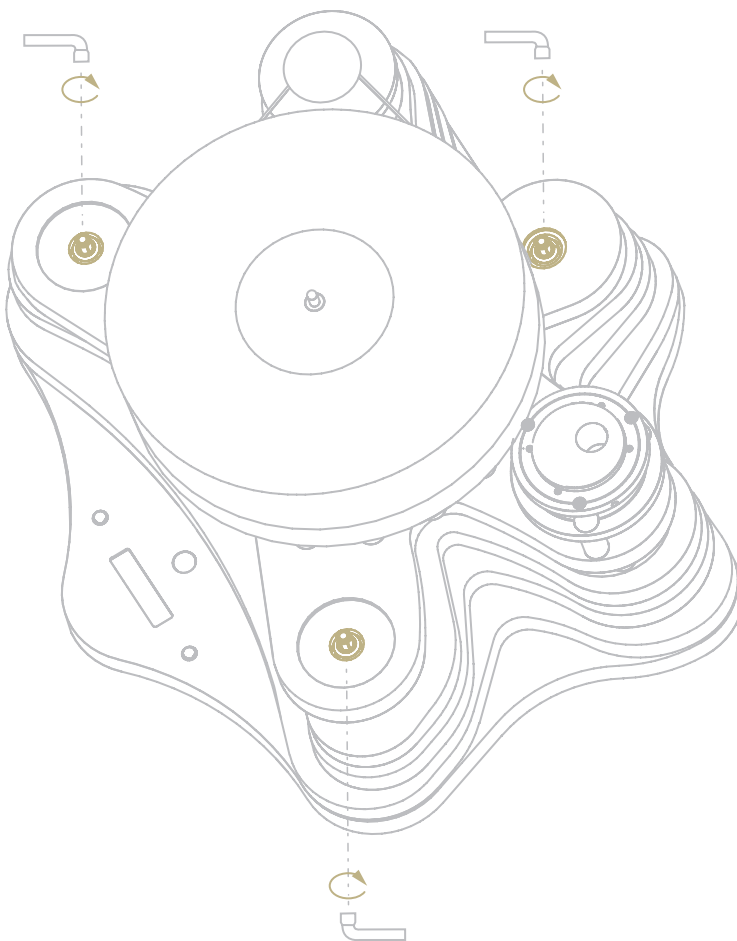

STEP 12

Take the 2 dome covers located in B5 and the conical cover located in B6.

Insert the dome covers onto the titanium supports located in front of the platter and the conical cover on the support located at the back.

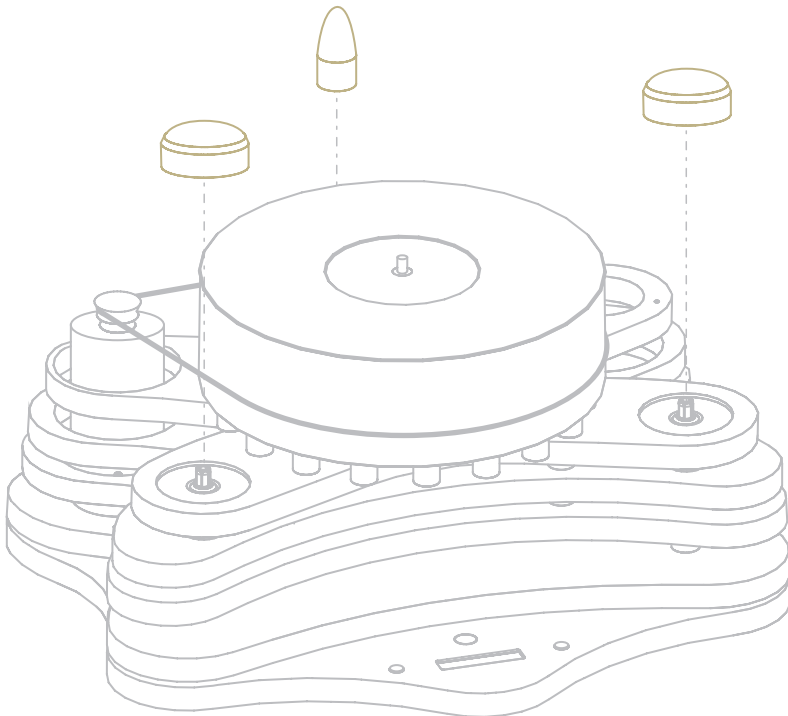

| POWER SUPPLY

POWER SUPPLY

The PST-10 is our best power supply specifically designed for our turntables, a perfect match for the Bellagio Reference. The power supply is already set for the Bellagio so you simply need to connect it to the power outlet and the motor.

Connect the mini-XLR cable to the dedicated port highlighted in the picture. Remember to switch on the PST-10 using the master switch located on the rear of the unit.

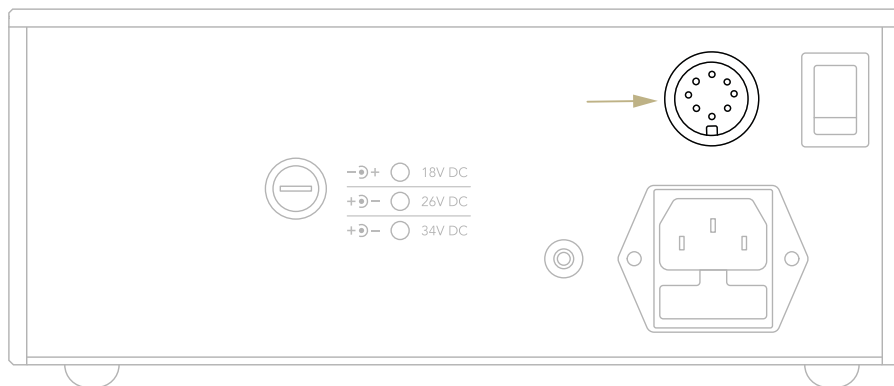

SPEED CONTROL & FUNCTIONS

SPEED CONTROL

The Bellagio Reference features an electronic speed control with dedicated buttons for the $33\frac{1}{3}$ rpm and 45rpm modes.

Press the left button to start the 45rpm mode, press the right button for the $33\frac{1}{3}$ rpm mode.

Press either button while the platter is spinning to stop the turntable.

STANDBY

To put the Bellagio Reference on standby mode, press and keep pressed both buttons for 3" while the turntable is not playing.

Once on standby, press and keep pressed either button for 3" to switch on the turntable.

PITCH CONTROL

The motor control allows you to adjust the pitch fine tuning the speed.

To adjust the pitch, press and keep pressed both buttons for 5" while the turntable is playing either in $33\frac{1}{3}$ rpm or 45rpm mode. The display will show PITCH.

Press the left button (45rpm) to increase the speed = pitch up
Press the right button ($33\frac{1}{3}$ rpm) to decrease the speed = pitch down

To exit the pitch control mode and save the settings, press and keep pressed both buttons again for 5" until the display shows the speed.

PLEASE NOTE: The pitch is stored into the turntable memory permanently so it won't be deleted even when in the case of a power outage.

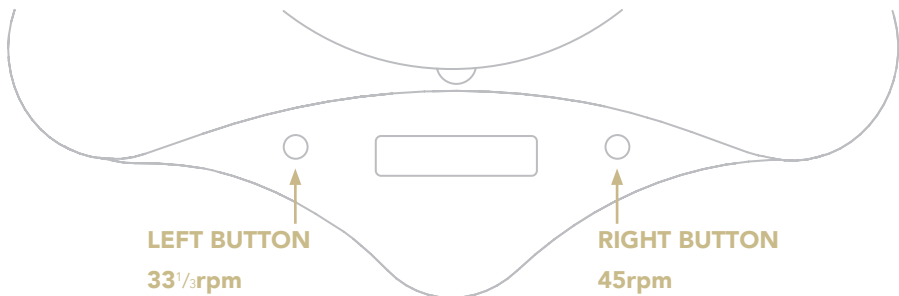

| VTA AND AZIMUTH SETUP

EN

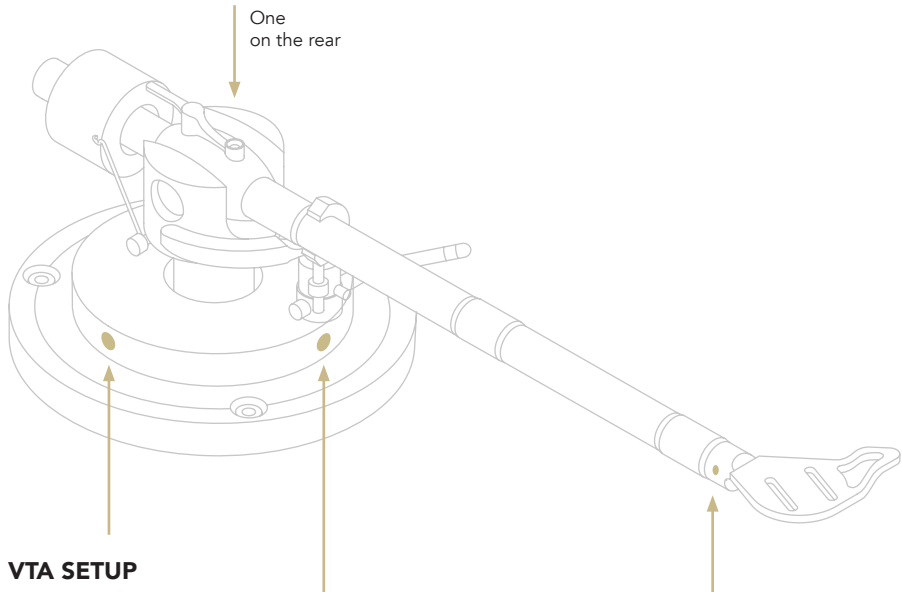

VTA SETUP

To up or down the arm by correctly adjusting the VTA, use the 1.5 mm Allen key supplied by Gold Note and insert it in the three holes on the arm board indicated by the arrows.

AZIMUTH

After the cartridge has been properly installed on the tone arm, you can adjust the angle of the headshell with the supplied 0,9 mm Allen Wrench. Setting a correct Azimuth will provide a better audio performance.

CARTRIDGE AND TONEARM CALIBRATION

Our turntables and tone arms are always supplied with the Gold Note Calibration Tool to calibrate correctly the setup.

With this tool you will be able to adjust:

- A** Phono Cartridge alignment.
- B** Overhang.
- C** 45rpm and $33\frac{1}{3}$ rpm speed (requires a strobe light).

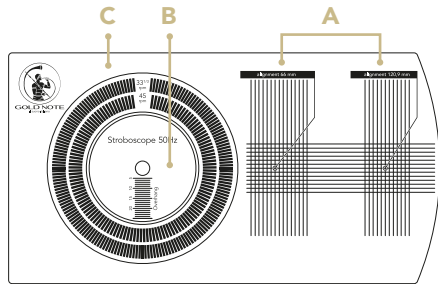

SPEED ADJUSTMENTS

Check the speed with the help of a strobe light (eventually a home NEON can also work). 120,9 mm. When the speed is correct you will be able to see the sequence of black rectangular signs as if they were stable and fixed while the platter is spinning.

The outer line is to check the $33\frac{1}{3}$ rpm.

The inner line is to check the 45rpm.

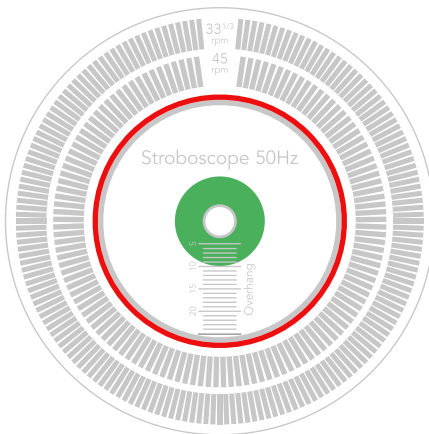

OVERHANG

To set the correct overhang the Calibration Tool must be inserted on to the turntable record pin and the cartridge Tip must be positioned on top of the pin.

Adjust the position of the cartridge until the suggested overhang of the phono cartridge is reached as indicated by the manufacturer.

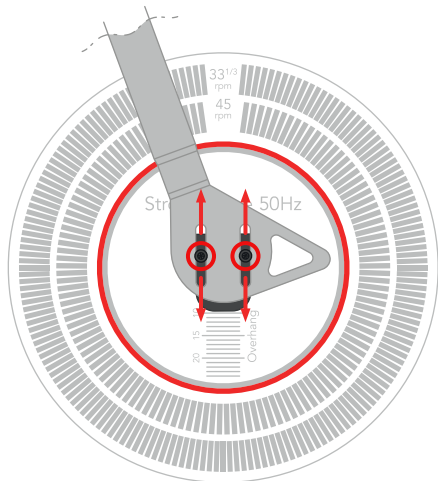

ALIGNMENT

To correctly align the phono cartridge and achieve the best tracking position, point the tip of the phono cartridge into the circles as in the picture below.

The body of the phono cartridge must be aligned to the vertical stripes in order to achieve the best position for musical reproduction.

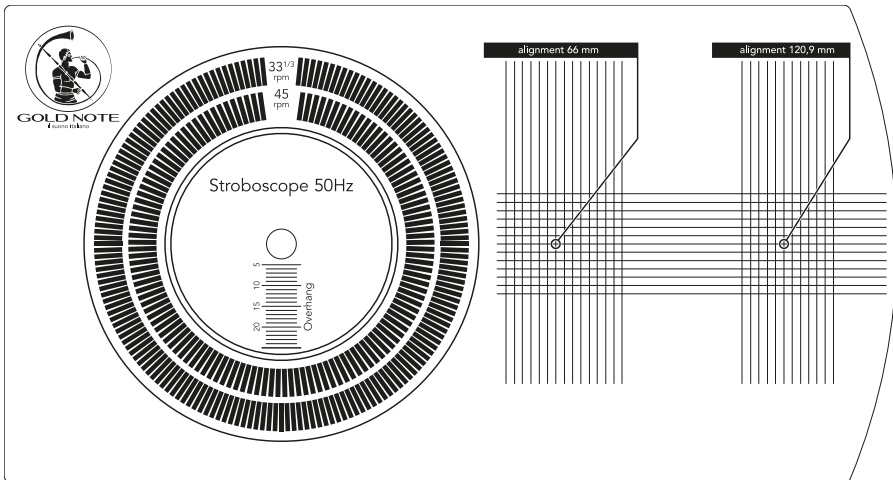
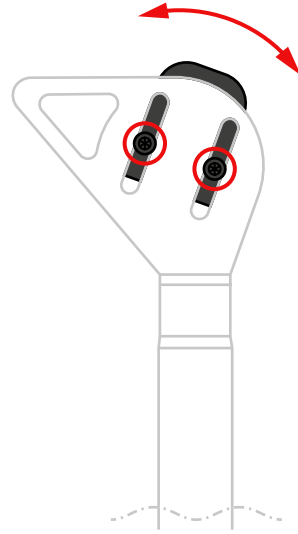

| PRODUCT REGISTRATION

PRODUCT REGISTRATION

We recommend to register the unit on our internet website within 15 days from the purchase at www.goldnote.it/product-registration

If the unit is not registered correctly or has been purchased from a different country of the purchaser home address the unit will not be covered by any warranty and the registration will be refused.

Please note that the warranty does not cover in any case: Tubes, Phono Cartridge Stylus and Batteries.



www.goldnote.it/product-registration

WARRANTY

All Gold Note products come with a warranty against defective materials and workmanship.

Any service and inspection must be carried out by a Gold Note dealer or distributor so in case you need any assistance with this product, please contact the seller.

If you experience any problems locating your official Gold Note dealer or distributor, please check our website or contact service@goldnote.it

PLEASE NOTE

Descriptions and technical characteristics may vary at any time and without notice.

WARNING

Gold Note products should only be opened, serviced and inspected by certified Gold Note technicians and dealers. Work performed by unqualified personnel may cause serious damage or personal injury. Opening of the product by non-authorized personnel will void the guarantee.

In this case, contact your dealer to be advised on how the fault can be solved.

Do not return any object directly to the factory or to the distributor without being authorised to do so.

| TROUBLESHOOTING

EN

PROBLEM	CAUSE	SOLUTION
Levelling the turntable.	<ul style="list-style-type: none">The turntable is not levelled.	<ul style="list-style-type: none">With a spirit level, only level the Turntable Platter through its shelf layer eventually screwing its feet just for very fine adjustment, take care of levelling the platter on its vertical and horizontal lines.Be sure that the turntable layer is enough solid and rigid to support the weight of the turntable Easily.
Cleaning the turntable.	<ul style="list-style-type: none">The turntable is dirty and requires cleaning.	<ul style="list-style-type: none">With EXTREME care use ONLY very soft 100% cotton cloth to sweep dust and stains out. Any acid, alcohol or not extremely soft cloth will irreversibly damage the turntable fine aesthetic.Only dry cloth is allowed.
Motor heating.	<ul style="list-style-type: none">The motor is too hot.	<ul style="list-style-type: none">AC synchronous motors as the ones used by Gold Note may warm up to 50° Celsius without creating any problem.
Noise on startup.	<ul style="list-style-type: none">The turntable produces a slight rubbing noise upon startup.	<ul style="list-style-type: none">It is normal for the belt to produce a slight noise when starting.

If you have any questions contact us at: service@goldnote.it

| RELATED PRODUCTS

CARTRIDGES

| TUSCANY

Our top-of-the-line MC cartridge, the result of over 20 years of experience, boasts an extra-thin Micro Ridge diamond tip and precisely hand-wrapped coils.

PHONO STAGE

| PH-1000

Our best phono stage ever, designed to be the perfect match for top-of-the line turntables. Featuring ultra-fine adjustments, limitless EQ curves, Class-A components, RCA and XLR inputs and a dedicated headphone output.

ELECTRONICS

| P-1000

High-quality Class-A line preamp with 8 XLR/RCA inputs and optional external power supply.

| PA-1175

Class-A/B power amplifier with variable Damping Factor technology for a perfect match with all types of loudspeakers.

LOUDSPEAKERS

| XS-85

Our flagship loudspeaker, a full-range 3-way design featuring a bass reflex port, top-quality crossover and the best materials and finishes.



Discover more on our website

www.goldnote.it



Designed and handmade in Firenze, Italy
www.goldnote.it
service@goldnote.it
copyright ©2021 Akamai S.r.l. All rights reserved